

Installation Recommendation

Methods/Preparation (Floors)

Let's start out by choosing a method. The method includes how the substrate will be prepared to receive the tile, the necessary materials, and can include the type of tile used. This will depend on the area in which you wish to tile and the level of performance required. What is the existing material and how is it supported? The most common types of supporting material are concrete slab and wood or steel framing covered with plywood or boards. In the section, Surface Prep these supporting materials are discussed, including how they should be prepared for tile.

Dr's Tip: Most industry standards for the specification of flooring methods are found in the current issues of the Tile Council of America's (TCA) Handbook for Ceramic Tile Installation, American National Standards Institute (ANSI) Manual, and the Marble Institute of America's Design Manual.

In choosing a method, the old saying "good, better, best" applies. Pick the best method your budget will allow. Failed installations are costly and avoidable. Have you ever heard the saying, "Why is there never enough time to do it right but always time to do it over?" Select a method that will suit the space and will provide the most stable surface for the tile. In addition, select a method that will give lasting performance. There are many variables. Probably the very best method for the installation of tile is a direct bond to a mortar bed or concrete slab. For a mortar bed, this is not always practical as the typical mortar bed and tile in the minimum thickness measures more than one inch. Depending on the application requirements, it can be greater than two and a half inches thick. There may not be room in an existing area for that thickness.

This is the primary reason so many methods have been tested and are approved. Tile can be set successfully in a variety of ways and on a variety of surfaces. There are adhesive Manufacturers that indicate within their literature that their adhesives will bond tile to tile, paint, epoxy coatings, seamless flooring, vinyl or asphalt flooring, plywood or paneling, hardwood flooring, and steel plate. It is mandatory that the Manufacturers instructions be closely followed in this case.

Current industry standards place floor use and service requirements into one of five categories. They are Residential, light, moderate, heavy, and extra heavy.

Residential encompasses "kitchens, bathrooms, and foyers." Light lists "light commercial such as office space, reception areas, kitchens, and bathrooms." Both of these classifications have numerous acceptable methods listed in the TCA Manual both for concrete slab and wood subfloor.

The Moderate class lists "normal commercial and light institutional use in public space of restaurants and hospitals." Heavy areas include "shopping malls, stores, commercial kitchens, work areas, laboratories, auto showrooms and service areas, shipping and receiving, and exterior decks." Extra heavy spans "extra heavy and high impact use in food plants, dairies, breweries, and kitchens." Extra heavy also dictates the use of tile rated for this extra heavy classification such as "quarry tile, packing house tile, or tile designated for this type of use by the manufacturer."

The interesting thing that occurs in these recommendations is that there are no recommendations for wood subfloor after reaching the moderate and higher levels except one in the heavy category where an epoxy double plywood floor is permitted.

This means that the recommended methods for floor systems in the moderate or higher range recommend the use of a concrete slab as part of the complete system.

Let's look at some typical residential and light commercial installations.

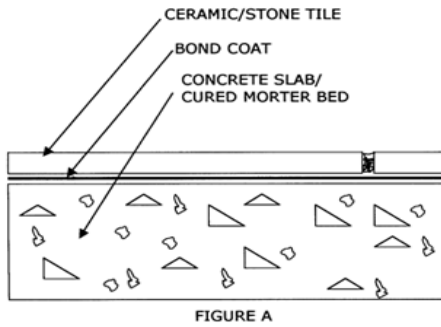

In Figure A, we see stone or ceramic tile placed directly over a concrete slab. This would be accomplished after the slab was fully cured and prepared to receive tile. This means that any cracks were repaired and any surface contaminants removed. This is a “thin set” method

Dr's Tip: Industry standards call for a “steel trowel and fine broom finish.” For tile directly over concrete slab.

This method can also be used with epoxy mortar and grout, organic-floor type 1 adhesives, and furan mortar and grout. Waterproof membranes/ anti-fracture membranes can also be used on concrete slabs if desired or required. As always; follow the Manufacturers recommendations carefully.

The tools necessary for this type of installation include mechanical scarifiers, cleaning tools, buckets, sponges, notched trowels, margin trowels, and layout and marking tools.

This method, by itself, should not be used on concrete subject to bending stresses like “structural concrete” or “post tensioned concrete.” If the concrete is subject to bending a different method should be chosen.

This can mean that a cleavage membrane and reinforced mortar bed, 1-1/4” min. to 2” max. thick, should be used below the tile and bond coat. Another way of dealing with bending stresses is in the new addition to this section found in Figure G.

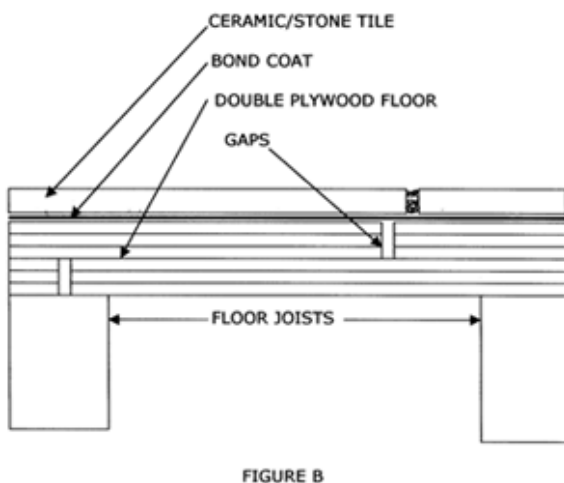

In Figure B, we see stone or ceramic tile bonded to a double plywood wood floor. Believe it or not, this is a good method where the thickness of the floor is a factor. This is a situation where the maximum thickness requirements prevent the use of a reinforced mortar bed and tile installation. This method can actually impart more resistance to deflection than cement backer board units.

This method should be used on light duty interior floors not exposed to moisture.

It is recommended that the sub floor is at least 5/8" plywood or 1" nominal boards and the overlay is at least 5/8" exterior grade plywood. No particle-board should be used. The 1/8" gaps are necessary for expansion/contraction of the plywood. Be sure that no joints match the framing below and that all joints overlap the joints below by at least 2." Use foam strips, caulking or duct tape to insure that no debris or setting materials gets into the joints.

The sub floor should be securely fastened to the framing members with screws or nails. If any squeaks or movement is detected, refasten where necessary. Use corrosion resistant screws or ring shank nails to fasten the overlay to the sub floor in a grid pattern 6" on center. The screws or nails should be at least 1-1/4" long to penetrate both sheets.

This method can be used with special "EGP" type Portland cement, organic floor type 1, and epoxy adhesives. Also, the method can be used with a special "proprietary membrane" like "Green Skin"

The tools necessary for this installation include fastening, layout and marking, notched and margin trowels, buckets, sponges, and tile cutting tools.

Dr's Tip: It is imperative that the Manufacturers recommendations be followed for this method.

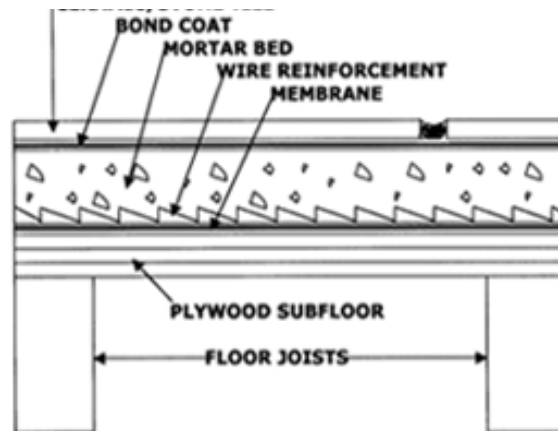

In Figure C, we see a typical residential mortar bed method. This method can be used over a structurally sound wood sub floor. For residential floors, a mortar bed thickness of 3/4" is acceptable. For light commercial duty floors, a 1-1/4" thickness is might be recommended. If a thicker floor was recommended, the suitable reinforcement could be 2"x2" 16/16 wire set in the middle of the bed for greater strength. This allows a greater thickness up to 2" is desired. Any mortar bed that needs to exceed 2" in thickness should be detailed by the architect.

This method employs a metal lath weighing not less than 2.5 pounds per square yard over a suitable cleavage membrane of 15 pound roofing felt, 4 mil. Polyethylene sheeting, or reinforced duplex asphalt paper fastened directly to the wood sub floor. The cleavage membrane needs to overlap at least 4". The metal lath and membrane should be fastened to the sub floor using corrosion resistant staples or nails capable of catching three strands of wire at each point. The fasteners should be spaced in a grid pattern 6" on center.

Incidentally, ANSI recognizes three acceptable reinforcing welded wire fabrics. They are 2"x2" 16/16, 2"x3" 13/16, and 3"x3"13/13 welded wire mesh fabrics. Also recognized are expanded metal lath fabrics in 2.5 and 3.4 pounds per square yard. The use of metal lath with raised ribs is not acceptable for tile work as it creates a weakened plane in the setting bed. When using expanded lath, the panels of fabric must overlap each other a minimum of 2". For welded wire, the panels must overlap a minimum of one mesh. I would always recommend the use of a corrosion resistant reinforcing fabric.

In actual use, building a mortar bed is not difficult nor is it something to be afraid of. Where the surface area is residential, the metal lath and cleavage-membrane can be attached to the sub floor. The installation of a mortar bed involves the use of deck mortar and float strips. The float strips are designed to set the height of the floated deck mortar. Float strips are commonly red wood lath, 1/4" thick by 1 1/2" wide. They can be cut to the desired length by saw or even a razor knife.

On floors, I often use a 1/2" thick "door stop" wood available at lumberyards. The 1/2" thickness is easier to set and gauge my height requirements. Whichever float strip is desired, make sure to fully moisten the strip before use. This keeps the strip from immediately sucking the moisture out of the mortar making adjustment difficult.

The installer determines where to place the float strips so that a straight edge can reach the maximum edges of the intended mortar bed. The installer fashions columns of mortar topped with float strips insuring that they are level in the column and are level with each other.

Then the installer trowels the deck mortar onto the lath between the float strips compacting the mortar as much as possible. The quality of the mortar bed depends on the installers ability to press the mortar firmly in to the wire mesh. Using the float strips as the guide, the installer cuts off the excess mortar placing the excess further down the area to be floated.

ANSI recommends the following mortar mixing ratios for deck or floor mortar. 1 part Portland cement (common cement), do not use plastic cement (needs to comply with ASTM C 150) to 5 parts damp sand (Needs to comply with ASTM C 144) and optionally 1/10 part hydrated lime (Needs to comply with ASTM C 206 or 207). Always try to use damp sand, as your batches will tend to be a little more consistent. If hand mixing, mix the dry ingredients with the damp sand first. Then add just enough water to fully moisten the mix. Good floor mortar will clump and stay together when squeezed in the hand. If machine mixing is desired, the water must be added to the mixer prior to the dry ingredients.

Dr's Tip: When mixing floor mortar, the key is to limit the amount of water in the mix. The more water, the more shrinkage.

The float strips must be removed while the mortar bed is still plastic or has not cured. After the strips are removed, the groove that is left must be filled with fresh mortar. This means that the installer has to move back onto a non-cured mortar bed or arrange the float strips in sections that can be removed while the float is in progress. If it becomes necessary to move back onto the non-cured bed, the installer can use "knee-boards" to accomplish this task. I prefer to arrange the float strips and stay off the bed of mortar.

When the method calls for a thicker mortar bed, the process is basically the same. However, the installer must suspend the reinforcing fabric into the approximate center of the bed by erecting small mounds of mortar to keep the fabric off the sub floor and cleavage membrane. The installer must be careful not to suspend the wire too much and end up having fabric poking out through the top of the bed.

Once the mortar bed has been floated, tile can be set immediately using a pure coat of Portland cement and water to form a trowelable paste. The tile, however, must be soaked in water for 1/2 hour or until completely saturated prior to setting. There must not be any standing water on the back of the tile. If the edges show signs of drying the tile must be re-soaked. Vitreous tile does not need to be soaked.

I prefer to allow the mortar bed to cure at least 24 hours. The tile can then be set in the manner described in Figure A.

The tools necessary for this type of installation include fastening, mesh cutting, membrane cutting, and layout and marking, margin and notched trowels, and tile cutting tools.

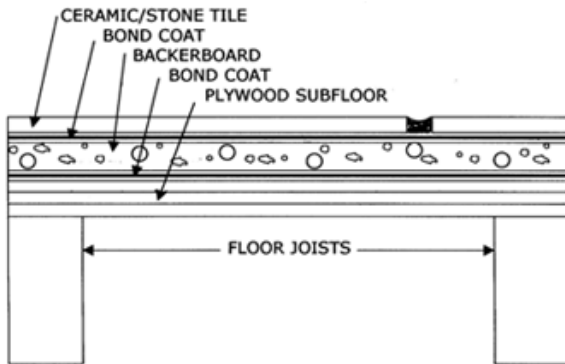

FIGURE D

In Figure D, we see a typical backer board installation. There are three basic types of cement backer board, cement fiber, glass mesh, and latex cement coated foam core board. Cement fiber backer units, described under ASTM C 1325, have mineral fibers within the body of the unit to give the board strength. The glass-mesh type, described under ASTM C 1178, is aggregates and cement encased with a fiber mesh for strength. These units are generally installed the same. However, it is the cement fiber units that offer greater water resistance. The installer should be careful to insure that the manufactured product meets the requirements that are desired for the given installation.

All backer boards must be used over dimensionally sound framing and sub-floor. As we discussed in Figure B, backer boards do not necessarily offer greater resistance to deflection. Backer units should be adhered to the sub floor in two ways. First the units should be applied to a freshly combed bed of dry-set Portland cement mortar.

Then the units should be nailed or screwed to the sub floor with corrosion resistant fasteners. Screws and ring shank nails should pass through the units fastening them securely to the sub floor. The fasteners should be applied in a grid pattern 6" on center.

The panels should be spaced 1/8" apart forming an open gap. The panels should be perpendicular to the sub floor panels. The gap should be filled with the bonding mortar and some Manufacturers require the gaps to be taped with alkali resistant joint tape imbedded in a fresh bond coat mortar. If the use of tape is required, the joint will need to cure prior to installing the tile. Follow the Manufacturers instructions.

Dr's Tip: Some Manufacturers require that certain types of adhesives and special fasteners are used with their product. It also may be necessary to fasten the units through the sub floor into the framing members. Make sure the recommended products and installation practices are used. This is the only way the Manufacturers will guarantee their product.

Backer boards are cut in a similar way that drywall boards are cut. They are scored with carbide scoring tool and straight edge. Then stressing the board by bending at the point of scoring snaps the panel.

Once the units are installed, they may be tiled using dry-set or latex Portland cement mortar and grout.

The tools required for this type of installation include fastening, layout and marking, cutting, margin and notched trowels, buckets, sponges, and tile cutting tools.

NEW INFORMATION

Recent tile flooring failures in the industry prompted the writing of this new addition to this section as of 2/2004. The following illustrations are very close to methods illustrated in the TCA manual found in methods F111-09, F112-09 and F122-09.

F111-09 is a mortar bed with a cleavage membrane and F112-09 is a mortar bed that is directly bonded to a concrete slab. F122-09 is a thinset method over a waterproof or anti-fracture membrane which is placed over a concrete slab. F125-09 and F125A-09 in the TCA manual deal with crack suppression membranes and their use.

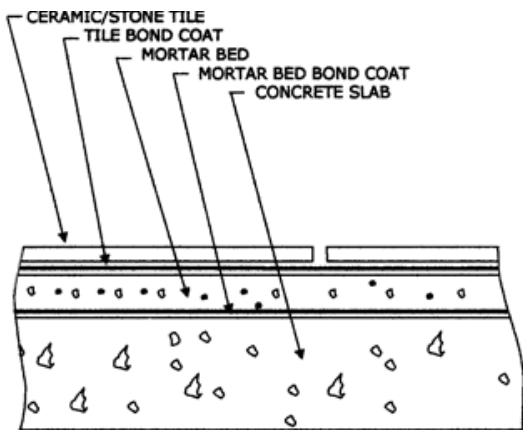

In Figure E (F112-09), we see a mortar bed directly bonded to a concrete slab. Note that there is no reinforcing shown in the illustration. The reason is that the concrete slab acts as the supporting structure to give the strength to the mortar bed. It is imperative, however, that the mortar bed be permanently bonded to the slab. If the bond were to separate, the mortar bed would lack sufficient flexural strength, under load and deflection, to maintain the integrity of the installation. Simply put, if the bond breaks, so will the tile above.

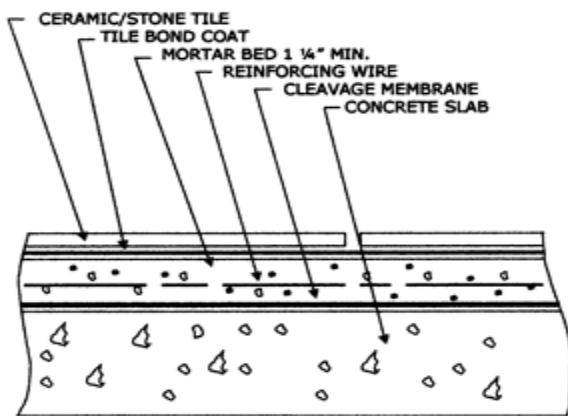

FIGURE F

In Figure F (F111-09), we see a mortar bed that rests above a cleavage membrane. Note the presence of wire reinforcing (2" X 2" 16/16 min.) in the bed. Note also the minimum thickness of 1 1/4" is noted on the illustration. The key difference is that the strength of this mortar bed depends on its own reinforcing and thickness to resist breaking from deflection and load above or below.

That is why this is the preferred industry method over structures that are subject to bending and deflection. This includes slabs constructed in the "post tensioned" method. Unfortunately, there is not always room for 1 1/4" of mortar bed and tile in today's structures. Read on to Figure G.

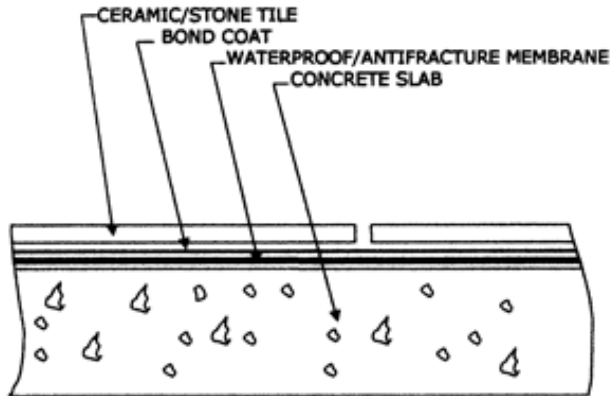

FIGURE G

In Figure G (F122-09), we see a classic example of a membrane bonded to a concrete slab. This represents either the entire slab covered with a membrane to waterproof it or to provide crack suppression (TCA F125A-09) beneath the tile layer. This can also represent crack suppression membranes in the area of known cracks and not a membrane applied to the entire slab.

Figure G is the answer to concrete slabs which have cracked or will crack. This is also a preferred method over slabs built in the post tensioned process where not enough room is available for a 1 1/4" mortar bed as shown in Figure F.

Dr's tip: In the case of any membrane which will be bonded to a concrete slab, the manufacturer's recommendations should be followed implicitly. The installation depends on the membranes ability to achieve and maintain a permanent bond with the concrete slab.

It should be noted that there are manufacturer's that produce thinset mortars that maintain their flexibility over the lifetime of the mortar and can successfully take the place of a membrane in the application of ceramic porcelain, or stone tile over a post tensioned concrete slab.

The reason for drawing attention to these methods is that they have been misused and failures have resulted in the industry. To solve the problem, the installer simply has to remember to have reinforcing wire in the approximate center of a mortar bed that is not bonded to the slab. If any membrane is placed between the mortar bed and slab, the mortar bed must be reinforced. This includes the various approved cleavage membranes and waterproof membranes whether sheet or liquid applied.

Tile Setting

Once the bond coat or setting bed has been trowelled, it is time to set the tile. Remember that it is a good idea to back butter tile larger than 8" or any tile where 100% coverage is desired. Set the tile in place and beat it in using a rubber mallet and beating block. For small tiles up to 6" use the beating block and mallet or just the rubber mallet for large tiles. The idea here is not to hammer the tile into place. The idea is just to firmly seat the tile into the setting bed. There is no need to exert great pressure on the tile. So, "softly" beat the tiles into the bed of mortar.

Once the tiles are placed and beaten in, align the tiles with your layout lines and clean off any bond coat residue from the tile surface. The bond coat should not interfere with the grout's ability to penetrate the joint by at least 2/3 of the joint depth.

At this point, the installer can apply spacers if necessary. Do not put them into the corner joints where the four corners meet. Simply place them in the joint between the tile. They therefore stick out from the joint. Once the tile has set and the thin set has hardened the tile into place, simply brush off the spacers and re-use them. I have found that removing spacers used in the traditional manner is difficult and the installer runs the risk of damaging the tile work in the process.

Dr's tip: Whatever use of spacers you choose, they should always be removed prior to grouting.

If the chosen adhesive is in the epoxy or organic class, carefully follow the Manufacturers instructions for their use. A word of caution about epoxy adhesives, all residues must be removed from the face of the tile, as it is difficult to remove after it has cured.

Tile Grouting

Let's talk first about Portland cement based grout since this is the most commonly used material. Once the grout is mixed per the Manufacturers instructions, it needs to be installed. ANSI recommendations for Portland cement based grouts used in tile work are described under ANSI 108.10. Be careful to allow the tiled installation to cure for the period prescribed by the adhesive Manufacturer prior to grouting. Some adhesives require longer curing time than the 24-72 hour normal Portland cement curing times.

This is a good time to carefully check the tiled installation for any adhesives that were left sticking out of the joints or left on the face of the tile. Thoroughly clean and inspect the tiled installation prior to starting the grout phase. I prefer to use a razor knife to scrape excess thin set or adhesive out of the joints.

For Portland cement grouts, it is a good idea to moisten the joints with water prior to applying the grout. This allows the grout to flow into the joint smoother and it prevents the tile from prematurely wicking too much water out of the grout. Do not leave puddled water in the joint prior to grouting. Check the Manufacturers instructions for the intended product for pre-moistening instructions.

Apply the grout to the tiled surface using a hard rubber grout float at a 45 degree angle to force the grout fully into the joint. Work in a small area applying enough grout to fill the joints. Do not work too large of an area. I recommend 2-3 square feet at a time for a novice. Use the grout float diagonally across the face of the tile finishing the grout flush with the face of the tile. In affect, you are "cutting" the grout excess off the tile.

The reason for working in a small area is simple. The grout will start to cure once it is applied. While it is still workable, it needs to be initially tooled into the joint. This means that the cutting off of excess and sponge finishing needs to be nearly complete before the curing begins.

Develop a plan to grout the floor so that you do not have to travel across freshly grouted joints. Try not to “paint yourself into a corner.” It might be a good idea to grout the floor in order in which it was tiled.

Dr's Tip: Remember to leave the perimeter joint open, this is a critical area for expansion. The perimeter joint can be filled with sealant or left open to be covered with base trim.

After the grout has been “cut off” the face, the next step is sponging the surface and tooling the joint. Tiles with a square edge need to have the grout finished flush with the tiled surface. Tiles with a cushion or radius edge should have the grout finished to the bottom of the cushion or radius.

This is accomplished by pulling the sponge across the face of the tile diagonally exerting just enough pressure to move the sponge. The idea is to clean the excess grout off the face of the tile and give the joint a smooth finished look. This will take a little practice and the technique can be learned quickly. Do not dig out the grout with too much sponge pressure and try to keep the sponging to a minimum.

Per ANSI 108.10, the joints should be “uniformly finished. Cushion edge tile shall be finished evenly to the depth of the cushion.” This means that grout joints should be uniform in color, smooth, and without pinholes or voids. The voids or pinholes can be filled and re-tooled with a sponge. Careful mixing of the grout combined with the lack of excess sponging should make the joints uniform in color.

Note: Grouting is a technique that requires practice, this is the reason for grouting a small area at a time.

If the tile you have chosen is easily scratched; it may be necessary to apply the grout to the joint alone. This can be accomplished with care using the grout float. Just be careful to not exert too much pressure on the face of the tile when using “sanded” grouts.

What if it is necessary to stop grouting and resume later on the same floor? This can be accomplished easily. It is always better to grout the entire installation at once. In this way, the chance of color variation and other problems are reduced. However, if it is mandatory to stop and resume later make sure that the grout in the finished joints is cut down to approximately 45 degrees to the substrate. Try to stop and start in an inconspicuous area as possible just in case a slight color variance does result.

In this way grouting can resume and the new grout can appear flush with the existing grout. The idea is to blend the new with the old. Of course, it is also important to make sure the area is clean and that no grout residue is left on the surface of any areas before ceasing work.

The grout work can then be polished using cheesecloth or towels to remove any grout haze after the grout has initially cured. If you were careful and thorough during the grouting process, the grout haze should be minimal. If there is stubborn residue, I use a fiber abrasive pad, which normally does the trick. In extreme cases of grout residue, the use of specific acids can be used like sulfamic or phosphoric. The acids should not be used prior to at least 10 days after the grouting was completed. Strictly follow the Manufacturers instructions for their use.

With few exceptions, Portland cement grouts should be “damp cured.” In fact, ANSI a 108.10 recommends it. Use only 40-weight “Kraft” paper for this process. Do not use “poly” sheeting or roofing felt. The “poly” sheeting will accumulate water that will drip on the grouted joints and discolor them by uneven curing time. The roofing felt can have the same effect and can leave tar residue on the tile and joints.

The paper is placed over the newly grouted surface and helps the grout to cure uniformly. This reduces the chance of color variance and produces a harder/denser joint. The commonly recommended curing time for Portland cement grouts is 72 hours.

Let's talk about epoxy grouts. They exist in two forms; water cleanable 100% epoxy setting/grouting described under ANSI A 108.6/A 118.3 1999 and modified epoxy emulsion mortar/grout described under ANSI A 108.9/A 118.8 1999. These adhesives and grouting materials must be installed per the Manufacturers instructions. These materials, when used for grout, are applied in a similar way to that of Portland cement grouts. However, the cleanup is accomplished in a much different way.

The Manufacturer will recommend a specific cleanup method for their product. Universally, the key is to allow the materials to acclimate to the room temperature in which they are to be installed for a period of 48 hours prior to their use. Remember these materials cure by chemical reaction, not hydration like Portland cement grouts. Therefore, temperature control is vital. It is recommended that they be used with a temperature range of 60-90°F. Definitely consult product literature for these parameters.

Dr's Tip: It is more imperative to remove excess grouting material from the tile face with these grouts. It can be much more difficult to remove than other grouts. Plus, acids do not remove epoxy-based products.

Concerning furan mortars and grouts, these grouts are the most difficult of all to work with. Sometimes their use is mandated due to expected chemical attack. The tile used in the installation must be pre-waxed prior to installation and grouting. The surface area must be steam-cleaned after the installation and grouting. The Manufacturers installation recommendations must be followed closely.

Let's talk now about a common problem associated most often with Portland cement based grouts in tile work. Efflorescence is a visible white powdery substance that is seen at times on the surface of grout joints. Efflorescence consists simply of dried salts that accumulate on the tiled surface left there by evaporating water. This salt, alkali in content, can leach up from the earth or simply be present in concrete substrates. When water moves up through the tile work, it brings the salts with it. When the water evaporates the salt is left.

Generally, efflorescence can be cleaned off the tile and joints by a good washing with pH balanced cleaners. In extreme cases, it can be cleaned with acid washing. As I said earlier, do not use any acids other than sulfamic or phosphoric. Absolutely use them according to the Manufacturers instructions. Remember that Portland cements are alkali based. Acid eats alkali, enough said.